



COMMERCIAL

DESIGNED WITH YOU IN MINDSM

GAS WATER HEATER POWER VENT KITS

Manufactured by Tjernlund Products, Rheem/Ruud Commercial Gas Water Heater Power Vent Kits are your best choice for new construction, electric-to-gas conversions and renovations.

Construction Features:

- Certified for use on natural and propane gas models.
- Maximum venting length up to 50 feet equivalent including the vent terminal.
- Vent terminal can be installed through combustible or non-combustible surfaces – heat shield is provided.
- Vent terminal is constructed from heavy-duty corrosion resistant aluminum.
- Venter can be connected to a vent termination on an exterior wall.
- Vibration isolators are supplied to provide quiet operation.
- Safety interlocks standard.
- Complete with mounting hardware.
- Venter is pre-wired with 40 feet of #18-4 copper wire (24 volt) to minimize field connections.

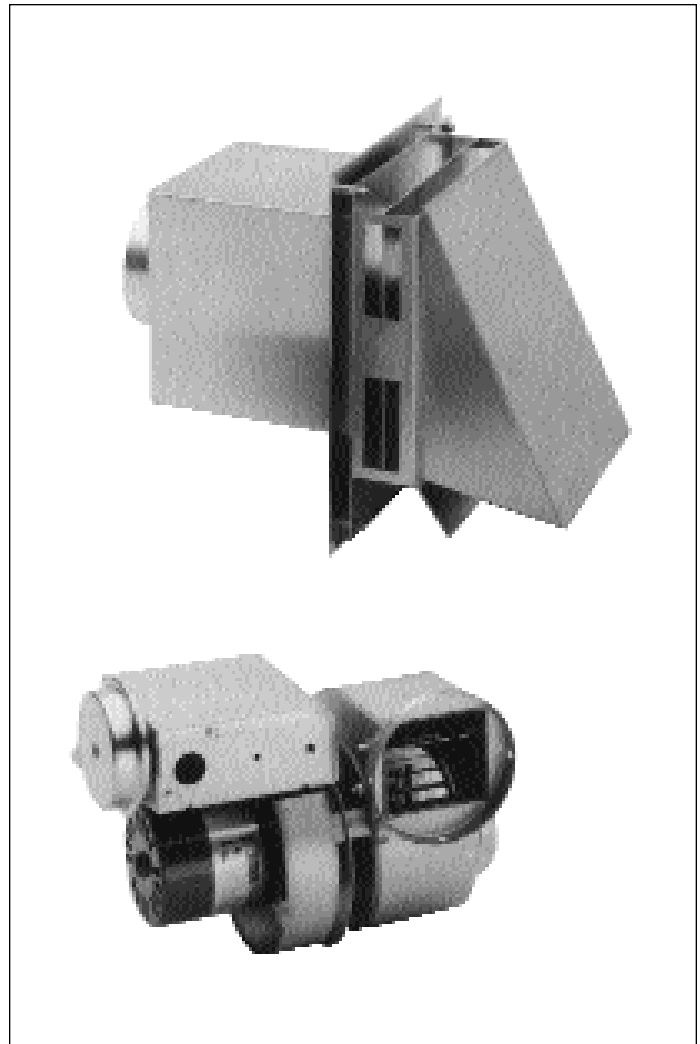

Certifications

Power vent kits manufactured by Tjernlund Products, Inc. are tested and certified by AGA for use on Rheem/Ruud Commercial Gas Heaters.



VENT KITS

Kit#	Part#	Applicable RHEEM/RUUD Water Heater Model
PV Kit 4	AP11646	G50-98, G67-114, G82-156, G37-160, G76-180
PV Kit 5	AP11645	G76-200, G91-200, G100-200, G72-250(A), G100-250(A), G100-270(A), G72-300(A), G91-300(A), G65-360(A), G65-400(A), G85-400(A)

DIMENSIONS

POWER VENTER (from Tjernlund)

Kit#	Motor Watts	Motor Amps	Max Vent	Height (H)	Width (W)	Depth (D)	Inlet Outlet
4	95	1.26	50 ft	7 $\frac{1}{8}$ "	11"	7"	4"
5	170	1.51	50 ft	9 $\frac{1}{4}$ "	11 $\frac{1}{2}$ "	8 $\frac{1}{2}$ "	6"

Note: Max Vent Length based on total length of straight vent pipe plus 10 feet for each 90 degree elbow and 5 feet for each 45 degree elbow.

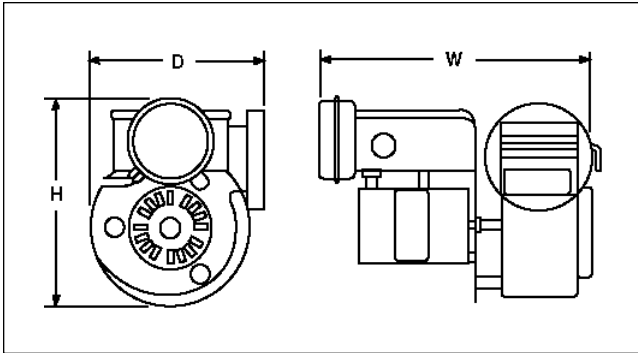

VENT TERMINAL

Kit#	A	B	C	Rough in Dimension
4	9"	9 $\frac{1}{2}$ "	7" Sq.	8" Sq.
5	10 $\frac{1}{2}$ "	9 $\frac{1}{2}$ "	8 $\frac{1}{2}$ " Dia.	9" Dia.

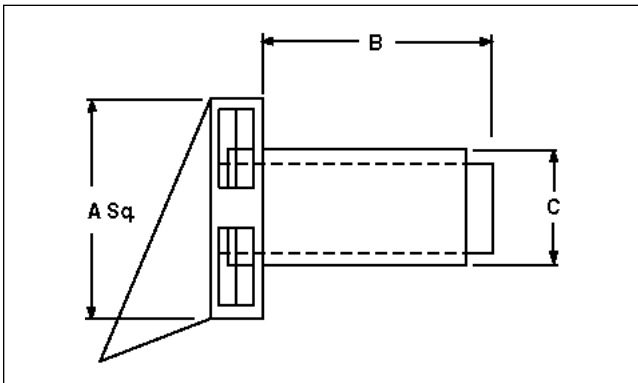

Model	Vent Kit	Draft Hood Outlet	Vent Size	Vent Adapter*
G50-98	PV Kit 4	5"	4"	5" x 4"
G67-114	PV Kit 4	5"	4"	5" x 4"
G82-156	PV Kit 4	6"	4"	6" x 4"
G37-160	PV Kit 4	6"	4"	6" x 4"
G76-180	PV Kit 4	6"	4"	6" x 4"
G76-200	PV Kit 5	6"	6"	Not Required
G91-200	PV Kit 5	6"	6"	Not Required
G100-200	PV Kit 5	6"	6"	Not Required
G72-250(A)	PV Kit 5	6"	6"	Not Required
G100-250(A)	PV Kit 5	6"	6"	Not Required
G100-270(A)	PV Kit 5	6"	6"	Not Required
G91-300(A)	PV Kit 5	8"	6"	8" x 6"
G72-300(A)	PV Kit 5	8"	6"	8" x 6"
G65-360(A)	PV Kit 5	8"	6"	8" x 6"
G65-400(A)	PV Kit 5	8"	6"	8" x 6"
G85-400(A)	PV Kit 5	10"	6"	10" x 6"

*Note: Vent Pipe and Vent Adapter are **NOT** included.

TYPICAL APPLICATION

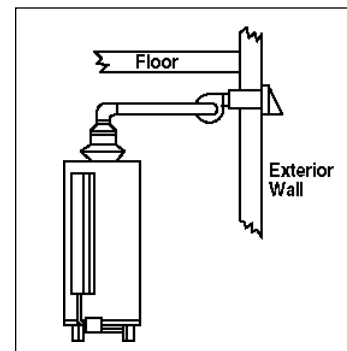

COMMERCIAL

DESIGNED WITH YOU IN MINDSM

RHEEM MANUFACTURING COMPANY, WATER HEATER DIVISION • 101 BELL ROAD, P.O. BOX 244020, MONTGOMERY, ALABAMA 36124-4020

"In keeping with its policy of continuous progress and product improvement, Rheem/Ruud reserves the right to make changes without notice."